

Virtual Chapter Chat COVID-19 Updates

Wednesday, May 13, 2020
6:00 – 7:00 PM

Call-In: (786) 535-3211
Access Code: 625-223-293
(Please ensure you are on mute)

American Academy of Pediatrics
DEDICATED TO THE HEALTH OF ALL CHILDREN™
ORANGE COUNTY CHAPTER



Welcome

Kate Williamson, MD
President, AAP-OC Chapter



Eric Ball, MD
Immediate Past President, AAP-OC Chapter

(Please ensure you are on mute)

AAP-OC Chapter Chat - Housekeeping

- Callers will be muted upon entering the call and will remain muted during the chat
- Use the chat box to submit comments or questions
- If you are on the phone for audio, please make sure your sound is off on your computer (this causes feedback)
- Do not put your phone on hold if you have to leave the meeting (we will hear the hold music)
- This webinar will be recorded and posted on the AAP-OC Chapter website



Who Are We & What Do We Do?

National, Chapter, & District Overview

Chapter: AAP-OC (California Chapter 4)

Who are We?

- ▶ Independent, yet “connected”; 501c3 nonprofit organization
- ▶ Youngest chapter of AAP National (1982)
- ▶ Designated as a “medium sized chapter” by members (250-499 FAAP members), but smallest by geographic size



AAP-Orange County Chapter

Our Mission: To achieve optimal health for all Orange County children by promoting pediatric excellence.

We accomplish this through:

- ✓ Excellence in Education
- ✓ Community Health Advocacy
- ✓ Legislative Advocacy



Become a Member!

- Free/reduced-price CME events for members
- Practice Support
- Networking
- Community Engagement
- Advocacy

Membership Dues: \$225/year

Chapter Affiliate: \$145/year

(Allied Health, Nurse, Parent/Family, Professional Staff, Non-healthcare)



How You Can Help



By making a donation to AAP-OC today, you will directly help children and families participating in our community programs that address pressing and current health issues facing Orange County's children.

Donate to the Chapter

- Provides support to our strategic priorities
- To be a "We Care for Kids" donor:
 - Go to <https://www.aap-oc.org/support-us/>
 - Click the "Donate" button on the Main Page

American Academy of Pediatrics
DEDICATED TO THE HEALTH OF ALL CHILDREN™
ORANGE COUNTY CHAPTER





COVID-19 Resources

The Hub for Children's Health in Orange County

American Academy of Pediatrics-Orange County Chapter provides evidence-based recommendations for child health to pediatricians, parents, professionals and public policy makers.

Visit our Website
www.aap-oc.org

And join us on social media

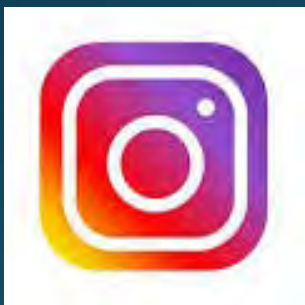

@ocaap



@AAPOCChapter4



@OCAAP

RETURNING TO SCHOOL:

WHAT WE ARE LEARNING FROM OTHER AREAS FROM OTHER AREAS AND
WHAT WE CAN DO NOW TO PREPARE

Marc Lerner, MD, FAAP

Pediatrician, The Center for Autism and Neurodevelopmental Disorders



See Which States Are Reopening and Which Are Still Shut Down

By Sarah Mervosh, Jasmine C. Lee, Lazaro Gamio and Nadja Popovich Updated May 13, 2020

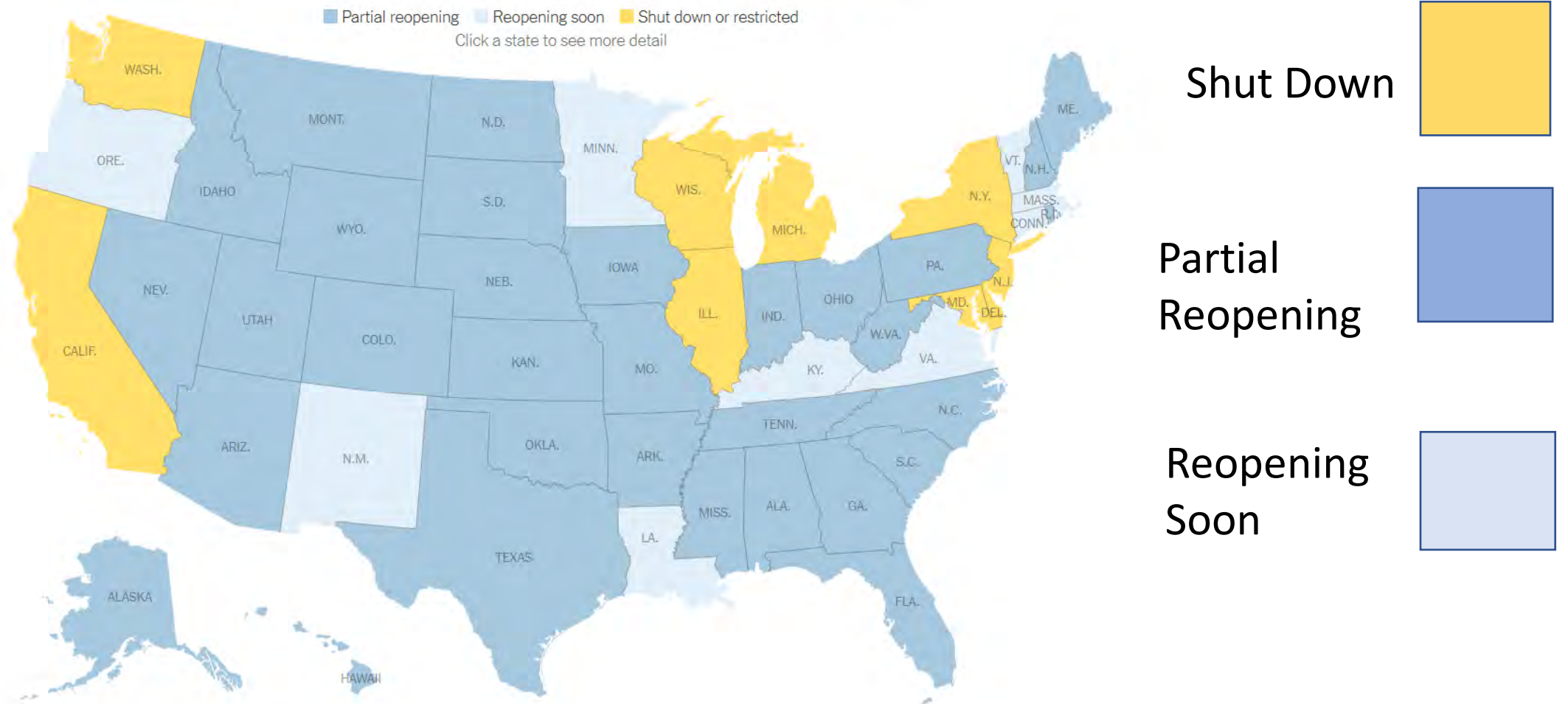

COVID Recovery: Phase 1

- Restrict to children of essential workers in areas needing significant mitigation.
- SCHOOLS AND ORGANIZED YOUTH ACTIVITIES (e.g., daycare, camp) that are currently closed should remain closed.

CDC Interim Guidance: Return to School

- Phase 1: Restrict to children of essential workers in areas needing significant mitigation.
- Phase 2: Expand to all children with enhanced social distancing measures. **SCHOOLS AND ORGANIZED YOUTH ACTIVITIES** (e.g., daycare, camp) can reopen
- Phase 3: Remain open for all children with social distancing measures.

Recent modelling studies of COVID-19 predict that school closures alone would prevent 2–4% of deaths, much less than other social distancing interventions.

[https://www.thelancet.com/journals/lanchi/article/PIIS2352-4642\(20\)30095-X/fulltext](https://www.thelancet.com/journals/lanchi/article/PIIS2352-4642(20)30095-X/fulltext)

AAP Statement: Return to In-person Education in Schools

- AAP supports collaborative decision-making among school districts and local and state public health departments about when it is safe to open schools
- Students across the country may have experienced educational loss due to prolonged school closures during this pandemic
 - The impacts of lost instructional time and social emotional development on children should be anticipated and schools will need to be prepared to adjust curricula and instructional practices accordingly
 - Nutrition is critical; school districts must consider ways to provide meals, including in non-traditional settings
 - Schools personnel should review the needs of each child with an IEP to determine the needs for compensatory education to adjust for lost instructional time and other related services
 - School districts may consider limited extensions for families to submit annual paperwork required for start of school; immunization compliance must be a priority
 - Students with high risk medical conditions may continue a distance learning program

School Class Sizes

- 20 elementary school children typically need 1,029 square feet of classroom area (36 feet by 30 feet = 1080 sq feet)
- 20 secondary students require 1,344 square feet
- CA Average KG Class size: 22 students
- CA Average 3rd Grade size: 23
- CA Average 6th Grade size: 27

New Class Design?

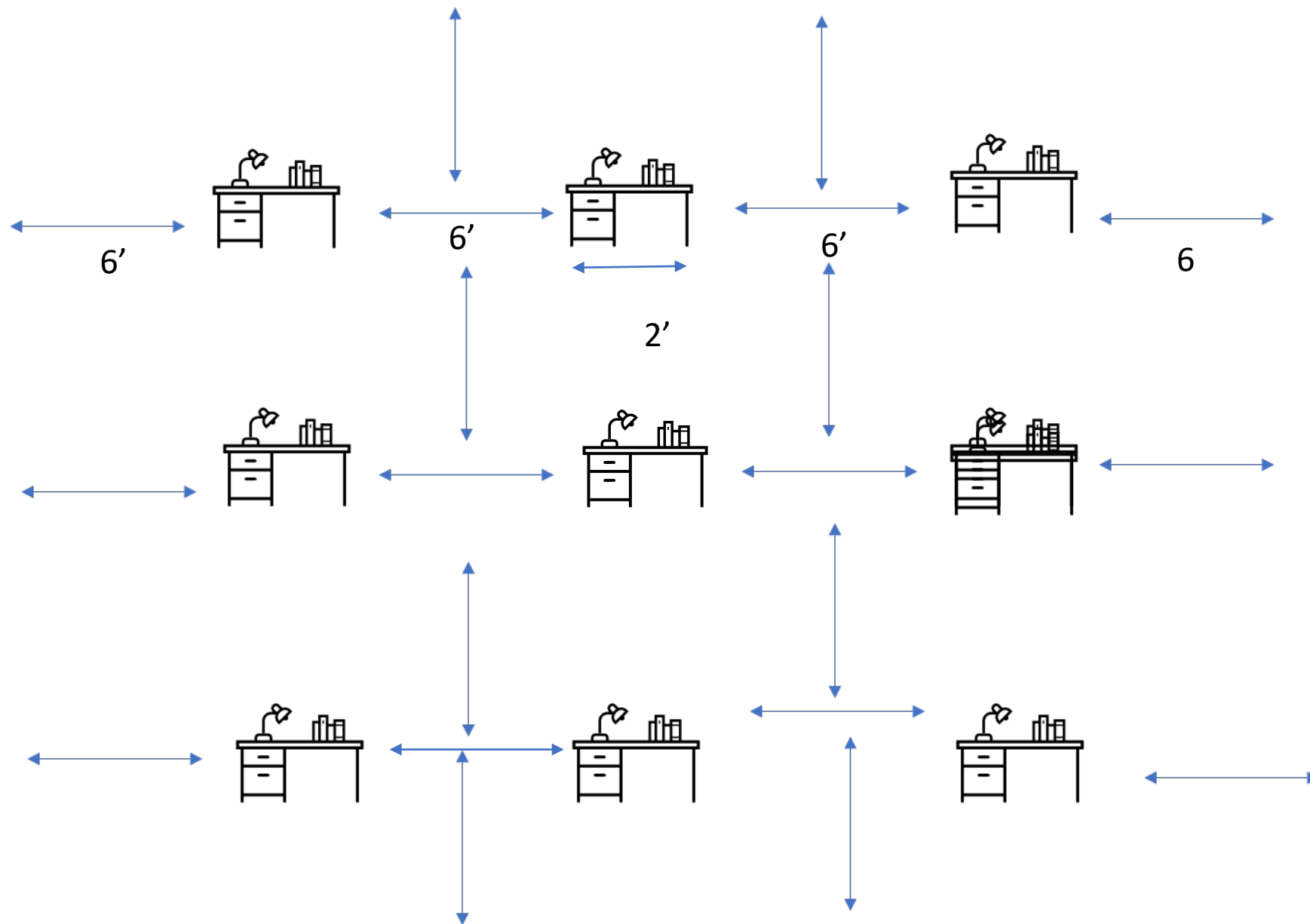

A Significant Portion of the School Workforce are at High Risk

Number of Teachers in Selected Age Groups - *CalEdFacts*

This content is part of California Department of Education's information and media guide about education in the State of California topics, visit the full [CalEdFacts](#).

Report of California public school teachers in selected age groups for the 2017–18 school year.

Age Group	Number of Teachers	Percentage of Teachers
Over 55	65,363	18.1%
46 to 55	99,756	27.6%
Under 46	196,599	54.3%
Not reported	0	0.0%
Total	361,718	100.0%

International Approaches to School Management Have Differed

Schools Never Closed	Schools That Recently Opened	Countries planning to reopen soon
Taiwan	Denmark	France
Cuba	Norway	Germany
Sweden	Japan	New Zealand
Turkmenistan	China	
Belarus	Israel	

Return to School: Taiwan

- <https://www.youtube.com/watch?v=wmK9Bt1xcnY>

Return to School: Taiwan

- Young children are encouraged to wear face coverings (brought from home), but they were not forced to.
- All staff members wear face coverings
- Temperatures are taken every morning for every child using infrared thermometers
- Students do not keep even 3 feet distance from one another, They are permitted to be close together.
- Students eat in the classroom at their desks, albeit with a flimsy barrier
- Students wash their hands before entering classroom.

Additional Issues:

- School-based Health Centers
- Homeless students
- Comprehensive Sexual Health & HIV/AIDS Instruction
- Contraceptive services delivered at schools
- Student mental health
- Student athletics (intramural / interscholastic)
- Schools and PPE

FIGURE. Weekly changes in Vaccines for Children Program (VFC) provider orders* and Vaccine Safety Datalink (VSD) doses administered[†] for routine pediatric vaccines — United States, January 6–April 19, 2020

Return

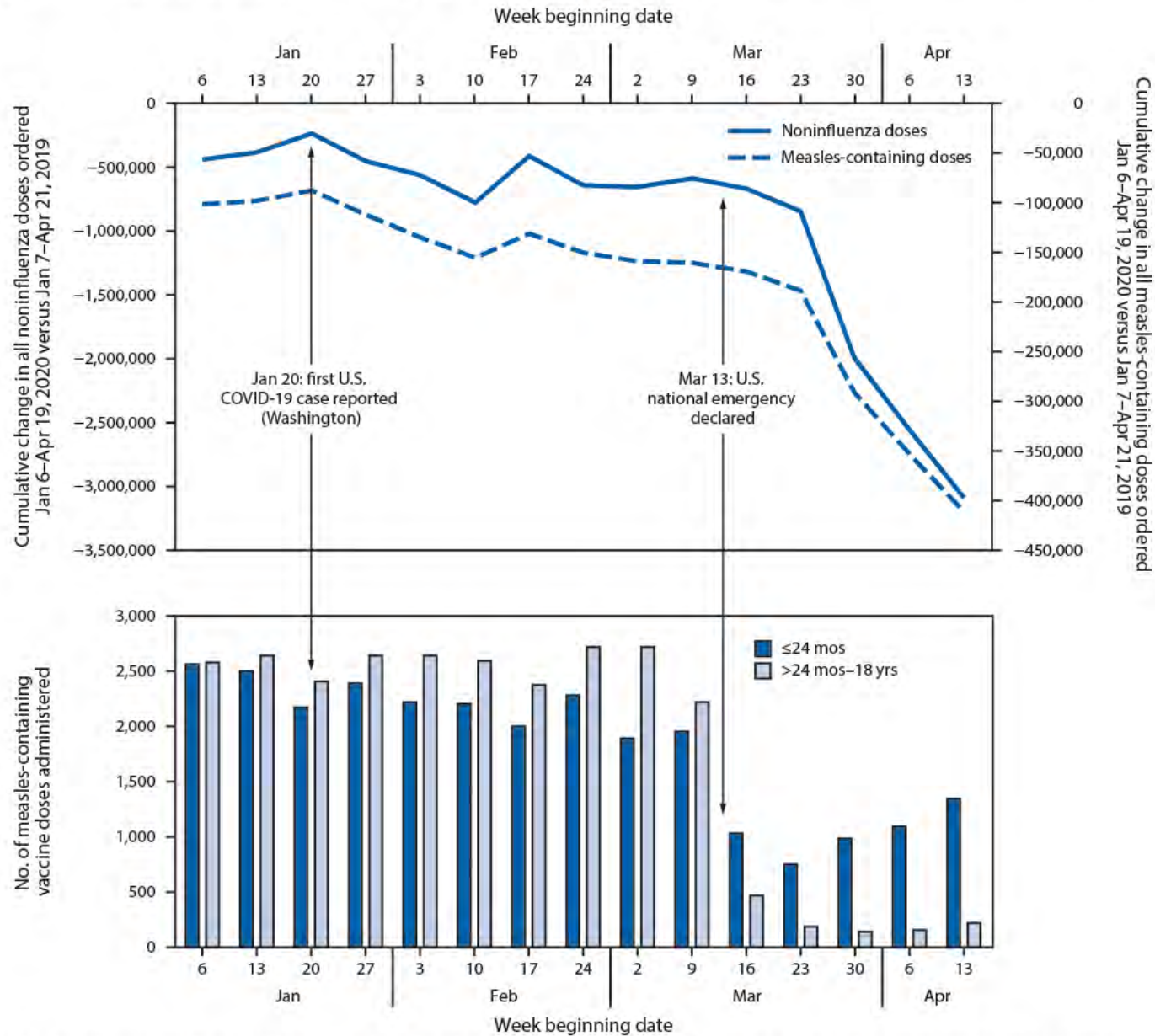

* VFC data represent the difference in cumulative doses of VFC-funded noninfluenza and measles-containing vaccines ordered by health care providers at weekly intervals^{††} between Jan 7–Apr 21, 2019, and Jan 6–Apr 19, 2020.

Improving Immunization Rates Top 10 Best Practice Interventions

1. **Establish Office Policy:** Require vaccine records at 1st appointment
2. **Review Vaccine Records** at Every Visit
3. **Vaccinate at Acute Visits:** Every visit is an opportunity to vaccinate
4. **Create a Culture of Immunization** with every Office Touchpoint: Messaging from office space, staff, website, social media platforms
5. Use **Non-Confrontational Communication** with Parents
6. Implement **Reminder & Recall Systems**
7. Utilize **Evidence-based Comfort Measures** for Immunization Delivery
8. Implement **Standing Orders** for “Vaccination Only” visits
9. **Train Staff & Clinicians:** Science & Schedule of Vaccines
10. **Institute a Culture of Quality Improvement:** PDSA Strategy



ADVOCATING FOR YOUR PRACTICE: INCREASING PATIENT VOLUME, MARKETING, AND SUSTAINABILITY

Colleen Kraft, MD, MBA, FAAP

Keck School of Medicine at the University of Southern California

2018 President, American Academy of Pediatrics

Division of General Pediatrics

Children's Hospital Los Angeles

American Academy of Pediatrics

DEDICATED TO THE HEALTH OF ALL CHILDREN™

ORANGE COUNTY CHAPTER





Advocacy: Your Patients Your Practice Your Message

Colleen Kraft, MD, MBA, FAAP

Chapter Chat, AAPCA-4



Topics

- Practice Data
- Meeting the needs of your patients
 - Well visits and immunizations
 - Chronic Care management
 - In person vs. telehealth
 - Marketing to families
 - Advocacy:
 - Local Leaders
 - Health Plan Medical Directors



Keeping Well

- Well care
- What if your child is ill?
 - COVID-19 symptoms
 - Other conditions
- Services for kids with special health care needs

Well Visits: Recommendations from the AAP



- Priority for children <24 months of age
 - In person as much as possible
 - Screenings (Anemia, lead)
 - Developmental screening
 - Immunizations
 - Growth
- Telehealth

How Are Pediatricians Responding?

- Morning hours for infants and toddlers only
 - In person, in the office
 - Screening for illness, both children and parents, prior to visit
 - Can perform all screenings and immunizations
- Early afternoon for mild illness that needs physical exam
- Telehealth and drive-through visits
 - Mornings for well care and immunizations
 - Temperature, weight/height, necessary screenings
 - Afternoons and evenings for fever/URI/cough
 - Outreach for chronic conditions (asthma, development)



Pediatric Telehealth in the Medical Home

- Families want their pediatrician to take care of their children via telehealth!
- Pediatricians can provide care in specific areas:
 - Developmental, Learning, School concerns
 - Behavioral health
 - Childhood obesity
- This will only be done if there is payment parity:
 - With in-person visits
 - At the office or “on-call” locations
 - With established patients, even in other states

Marketing

- Phone calls
- Email
- Social Media
- "Open for Business"



California Department of Insurance



RICARDO LARA
Insurance Commissioner

Search

Need help with insurance? Call
Call 800-927-4357

Se Habla



[File a Complaint](#)

[Consumers](#)

[Seniors](#)

[Agents & Brokers](#)

[Insurers](#)

[Fraud](#)

[News](#)

[About Us](#)

[About Us](#) / [Contact Us](#)

Contact Us

Hotline Telephone Numbers

Consumer Hotline	1-800-927-4357 (HELP) 1-800-482-4833 (TTY) or send us an email
Licensing Hotline	1-800-967-9331
California Low Cost Automobile Program ..	1-866-602-8861

CDI Headquarters Offices

Los Angeles Office

300 South Spring Street, 14th Floor
Los Angeles, CA 90013

Oakland Office

1901 Harrison Street, 6th Floor

Translate this page with [Google Translate](#)

[About Us](#)

[Meeting Requests](#)

[About the Commissioner](#)

[About the Department](#)

[Commissioner Appointments](#)

[Career Opportunities](#)

[->> Contact Us](#)



Assemblyman Bill Brough

Government Official

Send Email

Home About Photos Videos More

Liked Search More

About

See All

I am honored to represent our district and to have the opportunity to work for positive changes in Sacramento.

4,150 people like this including 1 of your friends



6,612 people follow this

<https://ad73.asmr.org/>



Assemblyman Bill Brough

April 19 at 6:35 PM

On Monday, I will be part of the Assembly's first budget oversight hearing about the Administration's pandemic spending. Tune in to: <https://bit.ly/326UVM4> - This will be the first of two hearings, reviewing what the Administration has allocated, spent or is in the process of spending for immediate needs to protect Californians during this uncertain time. Public testimony will be taken by telephone with a number to be provided during the public comment period.

The Department... See More



ASSEMBLY.CA.GOV

Today's Events | Assembly Internet

Virtual Advocacy Visits!

- Invite via your Telehealth Platform!
 - Local community leaders
 - Local legislator
 - Local Health Plan medical director





Telehealth in Pediatrics

- Medical Home
- Established patients
- Paid at parity
 - From Office or on-call
- Longitudinal care
- Coordinated care

Coordinated Care is cost-effective care

- Timely access
- Fewer inappropriate treatments (antibiotics, steroids)
- Fewer emergency department and urgent care visits





Pediatricians + Families

- You're open for business
- Well in person and by telehealth
- Immunizations—in office or “drive-by”
- Reach out to your patients to bring them in
- Marketing and Advocacy

OUR PEDIATRIC OFFICE IS OPEN DURING COVID-19 CLOSURES!

The COVID-19 pandemic has changed many things. But one thing is still the same...
Children Need their Check-Ups!



The AAP encourages families to continue visiting their pediatrician to keep children healthy & on schedule.

Your child's pediatrician is available for you to schedule your child's next well-check visit for the following and more:

Growth & Development



Is your child's development on track?

Mental Health



How is your child coping during this pandemic?

Nutrition



Is your child getting all necessary nutrients?

Immunizations



Is your child safe from other preventable diseases?

Contact Your Provider's Office

When you make an appointment, ask any and all questions about your child's health or COVID-19. Your provider is happy to answer them and help!



American Academy of Pediatrics
DEDICATED TO THE HEALTH OF ALL CHILDREN™
Orange County Chapter



American Academy of Pediatrics - Orange County Chapter - www.aap-oc.org

American Academy of Pediatrics
THE HEALTH OF ALL CHILDREN™
ORANGE COUNTY CHAPTER



Become an AAP-OC Chapter Member

American Academy of Pediatrics
DEDICATED TO THE HEALTH OF ALL CHILDREN™
ORANGE COUNTY CHAPTER



MEMBERSHIP APPLICATION

AMERICAN ACADEMY OF PEDIATRICS — ORANGE COUNTY CHAPTER (CALIFORNIA CHAPTER 4)

First Name: _____ Middle/Maiden: _____ Last Name: _____

MD DO Other (Specify): _____ Male Female

Preferred Address & Phone Home – or – Office

Institution/Organization Name (if applicable)

Number/Street/Suite

City/State/Zip or Postal Code/Country

Phone: _____ Fax: _____

Home Work Cell

Email Address

Please indicate your training:

A) Primary Care Pediatrics B) Pediatric Subspecialty – Please indicate: _____

C) Other: _____

Categories of Chapter Membership: (Please Check ONE) (See below for descriptions)

<input type="checkbox"/> Fellow/Specialty Fellow \$225	<input type="checkbox"/> Resident Fellow \$0
<input type="checkbox"/> Emeritus/Retired Fellow \$50	<input type="checkbox"/> National Affiliate \$225
<input type="checkbox"/> Associate Member \$225	<input type="checkbox"/> Physician/Dentist Chapter Affiliate \$225
<input type="checkbox"/> Candidate Member \$225	<input type="checkbox"/> Chapter Affiliate \$145
<input type="checkbox"/> Post Residency Training Member (First 2 Years After Residency) \$95	<input type="checkbox"/> Chapter Affiliate Student \$0

Payment:

My check for _____ is enclosed – Check # _____

PLEASE MAKE YOUR CHECK PAYABLE TO: California Chapter 4, AAP

I would like to include a donation of _____ to CA Chapter 4, AAP

I will pay using a credit card: Visa Mastercard AMEX Discover

Amount \$: _____ • Cardholder Name: _____

Card Number: _____ • CVV: _____ • Exp. Date: _____

* If you prefer to give credit card information over the phone, please call AAP-OC at (949) 752-2787

www.aap-oc.org/membership

Support our Chapter

www.aap-oc.org/support-us

American Academy of Pediatrics
DEDICATED TO THE HEALTH OF ALL CHILDREN™
ORANGE COUNTY CHAPTER



Thank You.

for participating in all of our chats!

Stay tuned for future CME and other virtual education and discussion

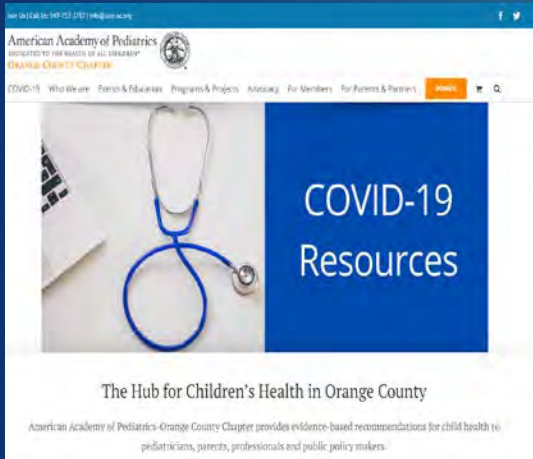

Visit our website...

www.aap-oc.org

...and join us on social media...



@AAPOCChapter4



@ocaap

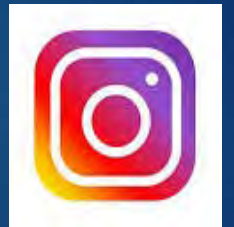

@ocaap

...to stay posted on our upcoming events!